

2500 Supreme Pumps

Installation, Operation and
Maintenance Instructions
with Parts List

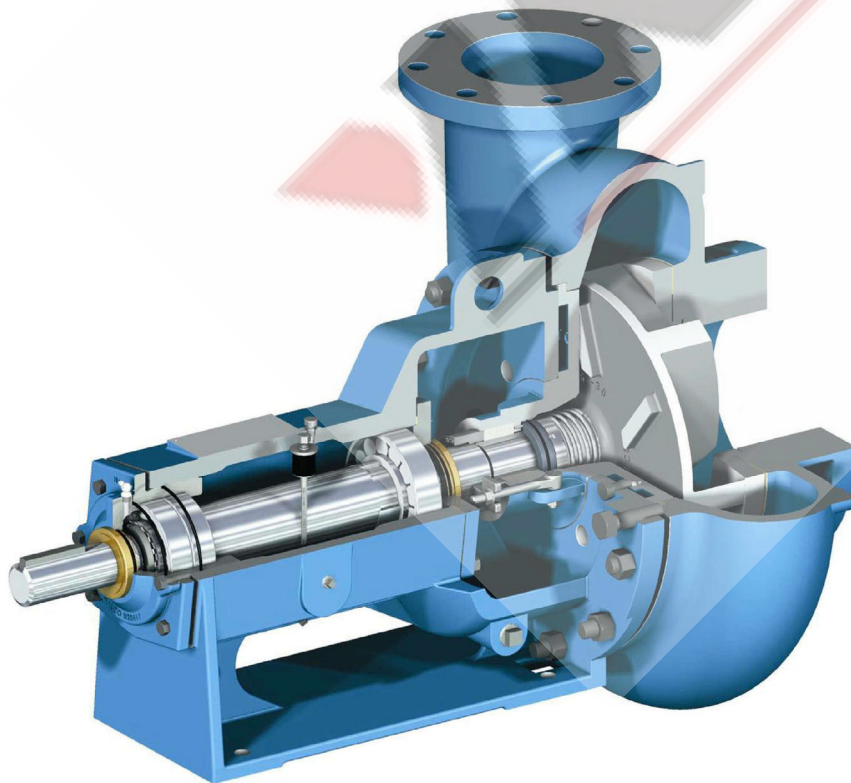
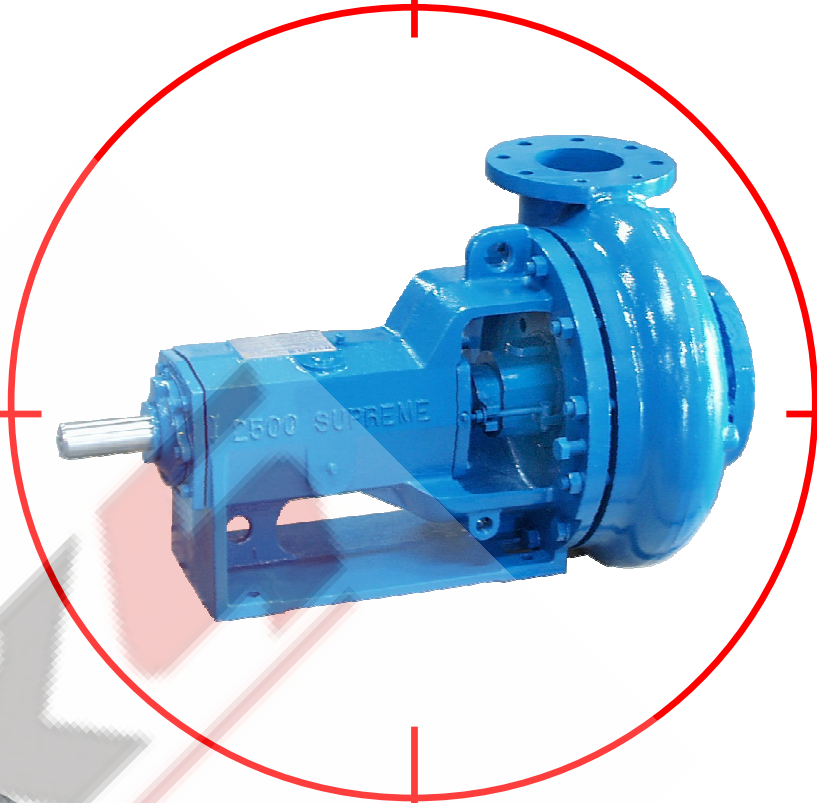

Bulletin No.
M500-1

Sales / Technical Information

EMAIL: terry@sdyks.cn

Internet: <https://en.sdyks.cn/>

P.O. Box 4638

Houston, Texas 77210-4638

Installation, Operation and Maintenance Instructions

Foreword...

This manual contains instructions for the installation, operation, and maintenance of the **NATIONAL OILWELL 2500 SUPREME**. As pump service conditions and specifications vary considerably in pump installation, this manual cannot possibly cover every situation, but it is intended that the information included will serve as a guide. Should questions arise, or start-up problems occur, it is suggested that you contact the NATIONAL OILWELL Pump Distributor or Salesman in your area.

The **2500 SUPREME** pump generation is an improved version of older 2 ½ inch shaft pumps. The **2500 SUPREME** pump is designed to give longer service life through a wear pad replacement casing, superior bearings, stainless shaft sleeve, labyrinth bearing cap seals, semi open impellers and stainless casing nuts.

There are many principles of proper pump installation and applications as well as special considerations for the **2500 SUPREME** design that, if followed, will further enhance its performance.

This document will deal with both general and specific recommendations for improved **2500 SUPREME** performance in both oilfield and industrial applications.

GENERAL INSTRUCTIONS

1. Operate the pump only in the performance range for which it was designed.
2. The pump driver must drive the pump **CLOCKWISE** when viewed from the coupling end. Reversing the rotation will damage the pump.
3. Do not operate the pump with the suction or discharge valves closed.
4. Adjust the packing so that a small amount of leakage remains for lubrication and cooling (not applicable for pumps equipped with mechanical seal).
5. When operating in drilling mud, prevent packing drippage from clogging the drip area and hardening around the slinger and front seal.
6. See Section E for mechanical seal installation.

 **! CAUTION ! CAUTION ! CAUTION !** 

EXERCISE SAFETY IN ALL PERFORMANCES: DO NOT IGNORE ANY WARNINGS, USE ONLY APPROVED METHODS, MATERIALS AND TOOLS. DO NOT PERMIT ANY FUNCTION OF QUESTIONABLE SAFETY; ACCIDENTS ARE CAUSED BY UNSAFE ACTS AND UNSAFE CONDITIONS. SAFETY IS YOUR BUSINESS AND YOU ARE INVOLVED.

 **! WARNING ! WARNING ! WARNING !** 

BEFORE PERFORMING ANY SERVICE FUNCTION, BE CERTAIN THAT THE UNIT IS SEPARATED FROM ITS POWER SOURCE OR THAT THE POWER SOURCE IS LOCKED-OUT TO PREVENT ANY FORM OF ENERGY FROM ENTERING THE EQUIPMENT. THIS WOULD INCLUDE ELECTRICAL OR MECHANICAL ENERGY INTO OR FROM THE PRIME MOVER(S), PNEUMATIC ENERGY FROM THE COMPRESSOR/AIR SYSTEM, ETC.

! WARNING ! WARNING ! WARNING !

FAILURE TO OBSERVE THE WARNINGS AND NOTES OF CAUTION IN THIS PUBLICATION CAN RESULT IN PROPERTY DAMAGE, SERIOUS BODILY INJURY, OR DEATH.

! ATTENTION - NOTICE - IMPORTANT !

THESE TERMS ARE USED TO DRAW ATTENTION TO ACTION THAT WILL CAUSE DAMAGE TO THE PUMP, COMPONENTS OR ATTACHMENTS.

! WARNING ! WARNING ! WARNING !

BEFORE SERVICING PUMPS:

1. SHUT DOWN OR DISENGAGE THE PUMP POWER SOURCE.
2. SHUT DOWN ALL PUMP ACCESSORY EQUIPMENT.
3. RELIEVE OR "BLEED OFF" ALL PRESSURE FROM THE LINES PRIOR TO REMOVING PIPING.

FAILURE TO SHUT DOWN POWER AND RELIEVE PRESSURE FROM THE PUMP BEFORE SERVICING CAN RESULT IN SERIOUS PERSONAL INJURY AND PROPERTY DAMAGE.

Table of Contents...

INSTALLATION

	<u>PAGE</u>
I. GENERAL	
A. Interchangeability	7
B. Location	7
C. Foundation	7
D. Coupling Alignment.....	8
E. Piping	
1. General	9
2. Suction	9
3. Discharge	9

PREPARATION FOR OPERATION

I. GENERAL	
A. Initial Lubrication (Oil lubricated pumps)	10
B. Mechanical Seals	10
C. Check Pump Rotation	10
D. Priming the Pump	10
E. Packed Pumps	11
F. Mechanical Seal Pumps	11
G. Start-Up Checklist.....	11

OPERATION

I. GENERAL	
A. Maximum Operating Conditions	12
B. Pump Records	12
C. Lubrication	
1. Bearings.....	13
a. Grease	13
b. Oil	13
2. Inboard Lip Seals	13
3. Packing	14
a. Grease	14
b. Water	14

Table of Contents...

MAINTENANCE

	<u>PAGE</u>
I. GENERAL	15
II. DISASSEMBLY	
A. General	15
III. INSPECTION	
A. Impeller	16
B. Shaft	16
C. Shaft Sleeve	16
D. Mechanical Seal	16
E. Bearings	16
F. Seals	16
G. General	16
IV. ASSEMBLY	
A. General	17
B. Shaft and Bearing Sub-Assembly	17
C. Power Frame Sub-Assembly	18
D. Assembly of Fluid End to Power Frame	19
E. Packing the Pump	20
F. Mechanical Seal	
1. H22451-1	21-22
2. H25001-1	23
V. EXCESSIVE PACKING LEAKAGE AND RAPID PACKING WEAR	
A. General	23
B. Packing Appearance	23
VI. INSTALLING WATER FLUSH SYSTEM TO BE ACCEPTABLE BY OIL COMPANIES	
A. General	24
B. Controlling Water Pressure to the Packing	24
C. Controlling When to Use Water on Packing	24
VII. BEARING FAILURES AND HOW TO IMPROVE BEARING LIFE	
A. General	24
B. Misalignment Between Pump and Driver	24
C. Detection of Bearing Failure When Pump is Running	24

Table of Contents...

MISCELLANEOUS INFORMATION

	<u>PAGE</u>
I. OPERATING LIMITS OF RIG CENTRIFUGAL PUMPS	25
II. SUCTION LINE VELOCITY	25
III. NET POSITIVE SUCTION HEAD (NPSH)	25
IV. CAPACITY LIMITS OF PUMPS	25
V. CAPACITY REQUIREMENTS OF EQUIPMENT IN RIG APPLICATIONS	26
VI. LONG TERM STORAGE	26

OLYMPIA™ DOUBLE MECHANICAL SEALS

I. GENERAL	27
A. Equipment List	28
B. Part Numbers	28
II. INSTALLATION and OPERATIONAL PROCEDURES	29-31
III. REMOVAL PROCEDURES	32-33

CROSS SECTION DRAWING	34
------------------------------------	----

PARTS LIST	35
-------------------------	----

Installation...

I. GENERAL

A. INTERCHANGEABILITY

2500 Supreme horizontal centrifugal pumps outside envelope dimensions are the same as older 2 1/2 inch pumps of the same nominal size so the models can be interchanged without changing existing piping, couplings, or bases.

B. LOCATION

The pump should be located near the liquid source so that the suction line may be short and direct. The pump should be located below the level of the liquid to eliminate the necessity of priming.

C. FOUNDATION

The foundation should be sufficiently rigid and substantial to absorb any vibration and support the base plate at all points. A concrete foundation, poured on a solid footing of adequate thickness to support the pumping unit, provides the most satisfactory foundation. The base plate should be installed in a level position.

Note: A detailed description of proper procedures for grouting base plates may be found in the Hydraulic Institute Standards, 13th Edition, Pages 116,117.

The rugged design of the frame and fluid end makes the **2500 SUPREME** more tolerant of improper foundations than many other pumps. When fabricated bases or fabricated skid bases are utilized, the foundation should be sufficiently rigid and level to absorb any vibration and support the base at all points.

Installation...

I. GENERAL (Continued)...

D. COUPLING ALIGNMENT

Good service life of the pump and driver depends upon good alignment through the flexible coupling. If the electric motor was mounted at the factory, the pump and motor were in alignment when shipped. **The alignment between the pump and driver should be inspected after installation to ensure that transportation or other handling has not caused misalignment of the unit.** Poor alignment may cause failure of the coupling, pump, motor, or bearings.

Alignment must not be attempted until the base is in position and the mounting and flange bolts have been tightened.

The recommended procedure for coupling alignment is with the use of a dial indicator, as illustrated in Figures 1 and 2. The dial indicator is attached to one coupling half with the indicator button resting on the O.D. of the other coupling half to measure offset misalignment. To measure angular misalignment, the indicator is positioned so that the buttons rest on the face, near the O.D., of the other coupling half. Rotate the shaft and dial indicator one revolution while the other shaft remains stationary and note the T.I.R. Unless otherwise specified by the coupling manufacturer, offset misalignment should be limited to 0.005 inches T.I.R. Adjust the alignment by loosening the pump or driver mounting bolts and retighten or shim as required.

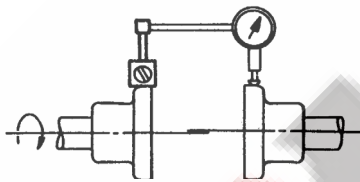

Figure 1
Measuring Offset Misalignment
With A Dial Gauge

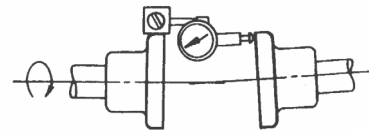

Figure 2
Measuring Angular Misalignment
With A Dial Gauge

In areas where a dial indicator arrangement is not available, an adequate job of alignment can be done with a straightedge. This method is especially useful if the coupling used contains a rubber drive element.

To check offset misalignment, lay the straightedge in line with the shafts on the O.D.'s of the coupling halves. There should be no gaps under the straightedge. Check two locations 90 degrees apart. Angular misalignment can be checked by measuring the gap between coupling half faces. There should be no more than a 1/64 inch gap under the straightedge or a 1/64 inch variation in the gap between the coupling halves. See Figures 1A and 2A.

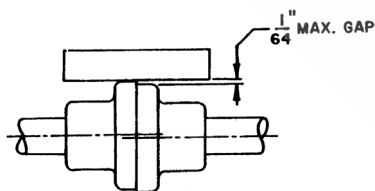

Figure 1A
Measuring Offset Misalignment
Using a Straightedge

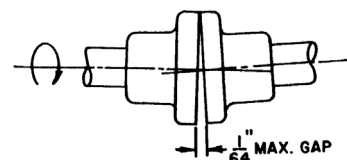

Figure 2A
Measuring Angular Misalignment
Using a Straightedge

NOTE: Further reference on coupling alignment can be found in Hydraulic Institute Standards, 13th Edition, Pages 177 and 120.

Installation...

I. GENERAL (Continued)...

E. PIPING

1. General

Piping must not be connected to the pump until the grout has hardened and the foundation and pump hold down bolts have been tightened.

Piping should be anchored independently of the pump and as near to it as possible. Pipe companion flanges should line up naturally with pump flanges. **Do not draw the pipe to the pump with flange bolts.**

2. Suction

Properly selected and installed suction piping is extremely important to eliminate vibration and cavitation in the pump. Vibration can cause packing problems, mechanical seal damage, or undue bearing loads.

The suction line should be equal to or larger than the pump suction. **The capacity of a centrifugal pump should never be adjusted by throttling the suction line.** A positive shut-off valve of a type to cause minimal turbulence should be installed in the suction line to permit the closing of the line for removal of the pump for inspection and maintenance.

The suction line should be designed to eliminate any air pockets. The piping should gradually slope downwards to the supply source to eliminate air pockets.

The suction line should have a straight section into the pump of a length equivalent to at least two times its diameter; i.e. a 4-inch suction line should have a minimum 8-inch straight run.

For temporary hook-up when flexible hose is used, a non-collapsing hose is essential since the suction line pressure is often below atmospheric pressure. A collapsed suction line will result in below average or complete loss of flow.

3. Discharge

A positive shut-off valve should be located in the discharge piping to permit the closing of the line for removal of the pump for inspection and maintenance.

All piping should be independently supported and accurately aligned. **The pump must not support the weight of the pipe or compensate for misalignment.**

If operating conditions are not known with sufficient accuracy, it will be necessary to provide a throttle valve in the discharge line to ensure that the pump operates at the design point.

If the pump is connected to a pressurized system, it is important to install a check valve between the pump discharge and the throttling valve. The check valve will prevent back flow through the pump. Back flow may cause the impeller to become loose on the shaft. A loose impeller will likely result in mechanical damage and fluid leakage beneath the shaft sleeve.

Preparation for Operation...

I. GENERAL

A. INITIAL LUBRICATION

Standard pumps are shipped Grease Lubricated with Chevron Duralith EP#2 Grease. See page 13 for lubrication instructions.

The air vent should be kept clean to prevent pressure build-up due to heating that occurs in normal operation.

Oil lubrication is available upon request. There is a dipstick available that indicates the correct oil level.

B. MECHANICAL SEALS

When mechanical seals are furnished they are installed and adjusted at the factory. The H22451-1 tungsten carbide mechanical seal normally used in drilling mud environments do not require external flush.

To properly prepare special or industrial mechanical seals for operation, various cooling and flushing flows may have to be connected. Liquid from an outside source may be required. If outside flushing is required, connect the necessary cooling or flushing lines to the seal and be sure they are operating before starting the pump. See seal drawings and instructions if special seals are used.

 **! WARNING ! WARNING ! WARNING !** 

NEVER OPERATE A PUMP "DRY" WITH MECHANICAL SEALS. MECHANICAL SEAL FAILURE WILL OCCUR!

C. CHECK PUMP ROTATION

Most pumps manufactured have clockwise rotation when viewed from the coupling end. The correct rotation can be found by an arrow on the casing.

It is very important that the pump rotation is determined before starting the pump. If the **2500 SUPREME** is turned backwards the impeller may unscrew causing sever damage to the pump.

The best way to check rotation is to disconnect the coupling, but it can be checked without disconnecting the coupling. One person should be at the pump watching the shaft while a second person starts and then immediately stops the pump so the shaft barely turns over.

D. PRIMING THE PUMP

Be sure the pump has fluid in the casing before running. If the pump is operated without fluid, the mechanical seal or packing can be destroyed. Vent air from the suction line and fill it with liquid. Start the pump with the discharge valve cracked open. After discharge pressure stabilizes, gradually open the discharge valve to the required position. If flow is lost, close the discharge valve and wait a few seconds for the discharge pressure to build. Continued flow difficulty indicates improper pump selection or installation.

Running the pump with improper priming may destroy the sealing faces of the mechanical seal due to overheating or mechanical damage from pulsation between stationary and rotating components. Do not run the pump with the suction valve closed **AT ANY TIME!** Thermal shock can crack the stationary seat if the temperature is raised from room temperature to 250° F. in less than 30 seconds. Run the pump with the discharge valves closed only for short periods of time. The energy going into the pump heats the fluid in the casing. If the pump needs to operate shut in some of the time, be sure to install a small line (1/4 or 1/2 inch) back to the suction tank between the discharge valve and the pump for cooling.

Preparation for Operation...

I. GENERAL (Continued)...

E. PACKED PUMPS

Loosen the packing on startup. The gland bolt nut should be only finger tight. New packing will expand faster with heat than older packing. Therefore, new packing must be adjusted more slowly than old packing. Too tight and it will not leak. With no cooling it will burn and be no good for sealing. **2500 SUPREME** pumps with mechanical seals have backup packing. This packing should be very loose and not tightened until seal failure occurs.

F. MECHANICAL SEAL PUMPS

Be sure the pump is never started dry. Seal faces will gall in less than a minute if run dry. The backup packing should not be tightened until seal failure occurs. The packing can then be installed and the pump run normally until the mechanical seal is repaired.

G. START-UP CHECKLIST

 **! WARNING ! WARNING ! WARNING !** 

IT IS ABSOLUTELY ESSENTIAL THAT THE ROTATION OF THE MOTOR BE CHECKED BEFORE CONNECTING THE SHAFT COUPLING. INCORRECT ROTATION OF THE PUMP FOR EVEN A SHORT TIME WILL DISLODGE THE IMPELLER AND DAMAGE THE IMPELLER, SHAFT OR BEARING HOUSING. THE PUMP SHAFT MUST TURN CLOCKWISE WHEN VIEWED FROM THE MOTOR END.

Check the following items before starting the pump:

1. Pump rotates freely by hand.
2. Pump rotates in proper direction.
3. Coupling aligned.
4. Oiler full and oil level correct (oil lube pumps).
5. Suction valve fully open.
6. Pump and suction line full of fluid.
7. Discharge valve is slightly open, not fully open. Fully open the discharge valve after the pump is running.

Operation...

I. GENERAL

A. MAXIMUM OPERATING CONDITIONS

Note: These maximum operating conditions apply to pumps that are exposed to room temperatures without external insulation.

1. Cast Iron: Maximum working pressure is 175 psig at 150° F or 150 psig at 250° degrees F. Interpolate for pressure between 150° and 250° F maximum.
2. Steel: Maximum working pressure and test pressure in accordance with ANSI B 16.5-1973, Tables 2.1 through 2.23 and Table 3.
3. For H-30 and SUPREME HARD alloy, contact NATIONAL OILWELL distributor.
4. Cooling water through the lantern ring is required when fluid being pumped is between 150° and 250° F. In addition, it may be necessary to run water over the exposed shaft to prevent excessive heat build up at the bearings.
5. Maximum hydraulic performance is in accordance with published performance curves.

B. PUMP RECORDS

Maintain data cards or pump records whenever possible. ***This will provide ready access to information for ordering spare parts and for evaluating pump and mechanical seal performance.***

Information to be included in these records should be:

1. Pump size and serial number.
2. Pump model number, impeller diameter, material of construction.
3. Mechanical seal manufacturer, type, code and drawing number.
4. Motor horsepower and speed of operation.
5. Service conditions.
6. Frequency of operation.
7. Record of maintenance, including parts usage and general pump conditions.
8. Nomenclature and part number of replacement items.

Operation...

I. GENERAL (Continued)...

C. LUBRICATION

1. Bearings

a. Oil

Oil lubricated pumps from the factory are equipped with a dipstick to check for correct oil levels. Use a good grade of 10W30 weight motor oil. Do not use a detergent oil as foaming can occur. There is also a plug on the side of the bearing frame. When adding oil, remove this plug. When oil runs out of the plug hole, the oil is at the proper level. Replace the plug. Do not overfill the oil. High levels may cause churning and overheating of the bearings. Oil should be changed every 1-2 months or 1000 hours.

b. Grease

Pumps are supplied from the factory grease lubricated unless oil lubrication is requested. Oil lubrication should be used whenever the pump speed exceeds 2400 RPM. The bearing caps have been drilled and tapped for grease fittings. NATIONAL OILWELL recommended bearing grease is Chevron Duralith EP#2 or compatible grease. Greases available in tubes are the best. Five shots with a standard hand operated grease gun of the above grease or equivalents in each bearing monthly is sufficient for twenty-four hour per day operation.

2. Inboard Lip Seals

The standard **NATIONAL OILWELL 2500 SUPREME** is equipped with labyrinth seals that do not require lubrication.

Also available is a lip seal. If your pump is equipped with a lip seal, the inboard bearing cover is supplied with a zerk fitting between the 9 and 10 o'clock position and a grease relief port located between the 3 and 4 o'clock position. **See Figure 3.** This is designed to create a grease barrier between the inboard lip seals. It should be greased prior to washdown and at least once a week with five (5) shots of general purpose or water pump grease. To properly grease the lip seals, first remove the grease relief port plug (3). This allows for the removal of old grease. Apply grease at the zerk fitting (1). Old grease from the seal will be forced out of the grease relief port. Replace the grease relief port plug. Bearing lubrication plug (2) is included in the drawing for clarity.

WARNING! FAILURE TO REMOVE THE GREASE RELIEF PORT PRIOR TO ADDING GREASE CAN FORCE OLD GREASE PAST THE LIP SEALS AND INTO THE BEARINGS, GREATLY SHORTENING THEIR LIFE.

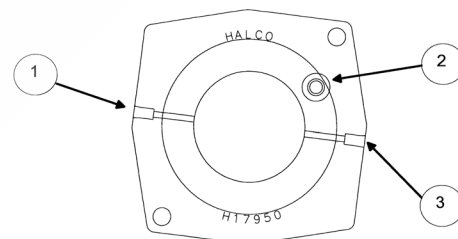

Figure 3

Operation...

I. GENERAL

C. LUBRICATION (Continued)...

3. Packing

a. Grease

The stuffing box may be re-lubricated with grease as often as necessary to prevent the packing from overheating. It should be lubricated at least once a day. It is best to install a spring loaded grease cup (NATIONAL OILWELL Part G1509) to automatically lubricate the packing. As you fill the grease cup a spring is compressed and a stem rises. As the grease is used the spring forces new grease to the packing and the stem lowers. When the stem is low the cup needs refilling. Grease should be pumped into the box while turning the shaft until it comes out around the packing gland (approximately 20 shots).

If the packing leakage is excessive, a thick water pump grease should be used rather than the general purpose grease. In most cases general purpose grease is acceptable.

b. Water

It is best to inject water into the lantern ring from an external source when pumping drilling mud. This will keep most of the solids out of the packing. PACKING AND SHAFT LIFE WILL BE INCREASED UP TO 500%. Also, water leakage from the packing will not be as objectionable as mud.

Maintenance...

I. GENERAL

Refer to Cross Section Drawing Fig. 10, Pg. 34, and Parts List on page 35 for materials and location.

II. DISASSEMBLY

A. GENERAL

1. Loosen packing gland bolts (6) and swing gland bolts to side. Remove packing gland halves.
2. Remove the casing nuts (1B).
3. Remove the casing (1).
4. Remove the impeller (2). **Note: The NATIONAL OILWELL Impeller Removal Wrench, Part No. H20952 is very useful.** The wrench fits over the motor end of the shaft and key. Turn the impeller very fast. When the wrench hits the workbench and stops an impact force either tightens or loosens the impeller depending upon the direction of rotation. If you do not have a wrench, restrain the shaft at the coupling end to prevent rotation while removing the impeller. Put a block of wood against the web between impeller vanes. Hit the wooden block with a hammer to **turn the impeller counterclockwise as viewed from the suction end.**
5. Remove the stuffing box cover bolts (3A).
6. Remove the stuffing box cover (3) from the frame by hammering on the back side of the cover in the area that the box fits into the frame. **Note: If the disassembly being performed does not require the replacement of the mechanical seal, the seal and stuffing box should not be removed from the pump. Once the seal faces have separated it is virtually impossible to re-mate the seal faces and obtain a positive seal.** Pull the packing (5B) from the stuffing box bore.
7. Remove the shaft sleeve (7A). A wedge may be driven between the end of the sleeve and the shoulder of the shaft to free the sleeve. Note: if the disassembly is being performed to replace or install a mechanical seal and/or shaft sleeve only, no further disassembly is required. See mechanical seal installation instructions below.
8. Remove the deflector (8) (no deflector is used on pumps with labyrinth seals).
9. Remove the plug from the inboard bearing cover (10A).
10. Remove the two through bolts (12B) on the outboard bearing housing. **These are bolts threaded into the frame (9).**
11. The complete shaft and bearing sub-assembly can now be pulled from the frame.
12. Remove the outboard bearing cover (13).
13. Bend the tab on the lockwasher (14A) back and remove the locknut (14B) and lockwasher.
14. Remove the bearing housing (12) and bearings (14) from the shaft. **Note: Impacting of the entire shaft assembly against a board on the ground will remove the outboard bearing assembly.**
15. The inboard bearing (11) may now be pressed off the shaft. **Note: A piece of 3" standard wall pipe slipped over the shaft and impacted against the inner race of the bearing works exceptionally well.**

Maintenance (Continued)...

III. INSPECTION

A. IMPELLER

Replace if impeller shows excessive erosion (especially on the pump-out vanes on the back of the impeller), corrosion, extreme wear, or vane breakage.

B. SHAFT

Check for runout to see that the shaft has not been bent. If runout exceeds 0.002 inch, replace the shaft. Bearing seats and oil seal area must be smooth and free of scratches or grooves. Shaft threads must be in good condition. Replace shaft, if necessary.

C. SHAFT SLEEVE

Sleeve surface in the stuffing box must be smooth and free of grooves. If grooved, replace.

D. MECHANICAL SEAL

Seal faces, gaskets, and shaft sealing members must be in perfect condition or excessive leakage may result. Replace worn or damaged parts.

E. BEARINGS

Replace if worn, loose, or rough and noisy when rotated. New bearings should not be unwrapped until ready for use. Replacement bearings must be of the proper size and type as supplied with the original equipment.

F. SEALS

It is recommended that all O-ring and gasket seals be removed during disassembly and replaced. In those cases where new seals are not available, the old ones can be reused if they are not torn or otherwise damaged.

G. GENERAL

All parts should be clean before assembly. This is especially important for retaining rings and O-ring grooves, threads, gasket surfaces, bearings, and bearing surfaces. Any burrs should be removed with crocus cloth.

Maintenance (Continued)...

IV. ASSEMBLY

A. GENERAL

Numbers following part names refer to the part as shown on the exploded view drawing (Fig. 10, Pg. 34).

B. SHAFT and BEARING SUBASSEMBLY

NOTE: Installation of the bearings with a press is an acceptable substitute for the following method. *Apply the load to the inner race only, when pressing the bearings onto the shaft.*

1. Heat the bearings to 400°F. **NOTE:** 45 minutes in an oven at 400°F will work nicely.
2. Slip the inboard bearing spacer and then the roller bearing (11) onto the shaft. **CAUTION: Bearings and spacer must shoulder against the shaft. Take care to ensure these pieces do not separate.**
3. With bearing housing seal (12A) in place, slide the bearing housing (12) onto the shaft from the coupling end. The large O.D. of the bearing housing should be facing the coupling end.
4. Slip the outboard bearings (14) onto the shaft. **Note: Outboard bearings are to be mounted back-to-back (that is, the sides of the bearings with the manufacturer's name and the bearing number are placed together). Improper bearing orientation will result in bearing failure. These bearings are a matched set and sets should not be mixed and matched. Check the installation requirements provided with the pump, and the markings on the bearings to help identify the "back-to-back" arrangement. Caution: Bearings must shoulder against the shaft.** Allow the bearings to cool. With lockwasher (14A) in place, tighten locknut (14B) with the bevel positioned against the bearings. Tighten the locknut to 250 ft./lb. of torque. Bend one tab of the lockwasher into the nut.
5. If grease lubrication is being used rather than oil, pack the bearings (11 & 14) full with grease, preferably Chevron Unirex N2 or compatible greases.
6. Grease or oil the outboard bearing (14) O.D.'s and pull the bearing housing over them into place. The outer races may be pushed in with a hand push or with a light tapping on the bearing housing with a rubber mallet. Install lip seal (13C) in outboard bearing cover (13) with the lip aimed in toward the bearings. Generously lubricate the rubber lip and the shaft in the sealing area. Fill the space behind the lip on the seal and half of the bearing cover with grease. If equipped with a labyrinth seal in lieu of lip seal lightly oil o-ring and press lip seal squarely into bearing cap.
7. Put cover seal O-ring (13B) in place. Slide the outboard bearing cover over the shaft. **Caution: Be careful not to cut the oil seal on the edge of the shaft keyway.** Secure two bolts (13D) and tighten evenly to approximately 20 ft./lb. of torque.

Maintenance...

IV. ASSEMBLY (Continued)...

C. POWER FRAME SUB-ASSEMBLY

1. Install inboard bearing cover seal (10C) into the inboard bearing cover (10) flush with the backside of the cover. Install exclusion seal (10F) flush with the outside of the cover. **The sealing lips on both seals should be pointed outward (away) from the bearings for grease lubrication, while the lip of (10C) points inward for oil lubrication.** Pack the area between the lip seals full with grease. If equipped with a labyrinth seal in lieu of lip seal lightly oil o-ring and press lip seal squarely into bearing cap. Using grease to hold it in place put the inboard bearing cover gasket (10B) on the cover.
2. The bores of the bearing frame must be clean. Lightly oil the bores to facilitate the insertion of the bearing train. Insert the shaft and bearing sub-assembly into the frame (9) until the threaded end of the shaft extends approximately halfway into the drip pan area.
3. The bearing train will slip in relatively easy by pushing the coupling end with one hand and pulling the opposite hand with the other. A rubber mallet may be used to tap on the end of the shaft assembly to help it align. **DO NOT USE EXCESSIVE FORCE.** If installation is difficult it indicates lack of concentricity between the bearings and frame. Excessive pounding will damage the bearings.
4. Slip inboard bearing cover assembly (10A) over the end of the shaft. Continue installing the shaft and bearing assembly in the frame until the gap between the frame and outboard bearing housing flange is approximately 1/4 inch.
5. Install two bolts (12B-1/2D x 1-1/2 inch) with jam nuts (12C) in the threaded holes in the bearing housing. Install the remaining two bolts (12B) through the unthreaded holes in the bearing housing and thread them into the frame. **Do not tighten any bolts.**
6. Bolt the inboard cover to the frame with bolts (10D-3/8D x 1-1/2 inch).
7. Lubricate I.D. of deflector (8) (not utilized on pumps with labyrinth seals). Slip the deflector on the shaft with the cup side facing away from the bearing cover.
8. Slip shaft sleeve seal (7C) onto the shaft and push it to the shoulder where the seal will seat. For pumps with a mechanical seal, see mechanical seal installation instructions on the next page for assembling the remainder of the pump.
9. The sleeved area of the shaft must be lightly coated with an anti-seize compound before installing the sleeve. Install sleeve (7A) with a twisting motion to spread the anti-seize compound. The gap between the sleeve and the shaft shoulder will be approximately 1/32 inch.

Maintenance...

IV. ASSEMBLY (Continued)...

D. ASSEMBLY OF FLUID END TO POWER FRAME

1. Lubricate the inside of the frame where the stuffing box cover slips in with an anti-seize compound. Install stuffing box cover (3) and secure with two bolts (3A-1/2D x 1-1/4 inch).
2. Lubricate the shaft threads and the face of the shaft sleeve with an anti-seize compound. Wash the O-ring with clean shop solvent and pat dry with a clean cloth. Install the O-ring into the impeller (2). Thread the impeller with impeller seal O-ring onto the shaft. Tighten to approximately 160 ft./lb. of torque.
3. Loosen the two through bolts (12B).
4. Draw the bearing housing rearward with the jam bolts (12B) while rotating the impeller. Stop when the impeller just touches the stuffing box cover.
5. Bring the through bolts up finger tight.
6. Loosen the jam bolts.
7. Tighten the through bolts until a clearance of 0.020 inch exists between the impeller back vanes and stuffing box cover (3). A hacksaw blade is approximately 0.020 inch thick and can be used as a gauge when no better tooling is available.
8. Advance both jam bolts until they touch the frame finger tight, and then tighten the jam nuts (12C).
9. Now tighten the through bolts down evenly. Rotate the shaft. **The impeller should turn freely without rubbing.**
10. Install casing gasket (1A). Hold in place with grease if necessary.
11. Apply a coat of anti-seize on all of the stuffing box cover diameters.
12. Install casing (1) on the frame using studs (1C) and nuts (1B). Put a small quantity of anti-seize compound on the threads on the nut end of the studs. Tighten the nuts to 140 ft./lb. of torque using a criss-cross tightening pattern.

Maintenance...

IV. ASSEMBLY (Continued)...

E. PACKING THE PUMP

1. Make sure the box is cleaned of all old packing and the plastic lantern ring.
2. Bend a wire and pull it down the shaft or shaft sleeve to ensure it is smooth for good packing life.
3. Grease all five shaft packing rings (5). Insert three packing rings alternating the splits in the rings from top to bottom starting with the split on the first ring on the bottom. If King type packing is being used, the rings should be installed with the lips toward the impeller.
4. Install the lantern ring with the split in the vertical position. The two halves of the packing gland (4) may be used to push the packing and the lantern ring together and to the bottom of the box.
5. Insert the final two packing rings. The objective is to have the last split down so that leakage will drip down and not have to go over the shaft and possibly in the bearings. If King packing is being used, insert the final King ring with the lip towards the outside and split on top, and follow with the single ring of square packing split down.
6. With the packing gland (4) in position, swing the gland bolts into place. Initially tighten the gland hard to compress the packing. Then back off the gland bolts and retighten only finger tight. **Caution: Tighten the gland against the packing finger tight only. If packing is over-tightened it may be burned when the pump is started.**

Maintenance ...

IV. ASSEMBLY (Continued)...

F. MECHANICAL SEAL

H22451-1 see below

H25001-1 see page 23

KCD SEAL – Olympia Double Mechanical Seal see page 27

1. H22451-1

- a. If the impeller and/or stuffing box are being replaced adjust the impeller clearance BEFORE installing the seal. Back the through bolts (12B) out approximately ¼ inch. Tighten the jam bolts (12B) until a clearance of 0,015-0.020 inch between the back of the impeller (2) and the stuffing box (3) is obtained. Alternately tighten the through bolts and jam bolts making sure that the clearance set above is maintained. Tighten the jam nuts and recheck the clearance.
- b. Make sure the shoulder where the stationary will sit and the inside of the stuffing box (3) is clean and that the 30° bevel on the 3-3/8 inch I.D. is free from burrs and sharp edges. Coat the I.D. of the stuffing box stationary seat packet with oil. Place the stuffing box on a table or other flat surface with the impeller side facing up.
- c. The slotted side must be installed away from the impeller or down when the stuffing box is positioned as described in step 2 (above). Coat the O.D. of the stationary seat and O-ring with a thin film of oil.
- d. Carefully install the stationary seat into the stuffing box. Be sure the groove of the stationary fits properly over the drive pin. Be sure that the stationary seats evenly against the stuffing box shoulder. **Hint: Wrap the end of a wooden hammer handle with a rag. Press firmly on the face of the stationary. Do not strike. Push gently on one side, alternating sides until the stationary is completely down.** Coat the stationary seat face with light oil, then wipe off the majority of the oil with a clean cloth, leaving only a light film.
- e. Lubricate the inside of the frame (9) where the stuffing box (3) slips in with an anti-seize compound. Install the stuffing box and secure with bolts (3A-1/2D x 1-1/4 inch). Care should be taken to prevent bumping of the stationary seal on the shaft end.
- f. Remove the rotating seal ring (4A of Figure 9) if it is not glued into position and store it in a safe place. Gluing can be determined by pulling on it gently. Coat the O.D. of the shaft sleeve (7A) and the I.D. of the rubber bellows (Item 4B of Figure 9) with a thin coat of oil.
- g. Place the sleeve (7A) with the impeller end up on a table. The impeller end is the end with the smallest I.D. With the sealing face of the rotary unit facing down and the rubber end up, gently ease the rubber bellows over the sleeve and push it to the bottom half of the sleeve. (It is not necessary to push it all the way to the bottom). If the rotating seal ring (4A) has been removed, lightly coat the face of the bellows (Item 4B of Figure 9) with grease. (This is necessary to hold the rotating seal ring in place during assembly). Reinstall the rotating seal ring into the cage assembly (Item 4C of Figure 9).
- h. Make sure no foreign material is present on the seal faces. Make sure the shaft (7) is free of nicks and burrs and is clean and dry. The sleeve area of the shaft, the shaft threads and the shaft face must be lightly coated with anti-seize compound before installing the sleeve (7A). Install the sleeve with a twisting motion. As the seal faces make contact, continue to push the sleeve through the I.D. of the rotary seal element until the gap between the sleeve and the shaft shoulder is approximately 1/32 inch.

Installation, Operation and Maintenance Instructions

Maintenance ...

IV. ASSEMBLY

F. MECHANICAL SEAL

1. H22451-1 (Continued)...

- i. Install the spring retainer (Item 9 of Figure 9) and the impeller O-ring (2A) in its groove and coat with anti-seize compound. Place the mechanical seal spring (Item 6 of Figure 9) over the rotary unit of the seal (which is inside the stuffing box cover).
- j. Thread the impeller (2) onto the shaft (7). Be sure that the spring engages in the retainer on the impeller. Tighten to approximately 60 ft./lb. of torque.
- k. Install the casing gasket (1A). Hold it in place with grease if necessary. Apply a light coat of anti-seize compound on the 14-1/8 inch diameter of the stuffing box cover. Install the casing on the frame using studs (1C) and nuts (1B). Put a small quantity of anti-seize compound on the threads on the nut end of the studs. Tighten the nuts to 140 ft./lb. of torque using a criss-cross tightening pattern.
- l. We recommend that the three shaft packing rings (5) are not installed until the seal fails. The rings are for emergency backup until the mechanical seal can be replaced. When they are installed, first grease them. Insert all packing rings alternating the splits from top to bottom starting with the split on the first ring at the bottom.

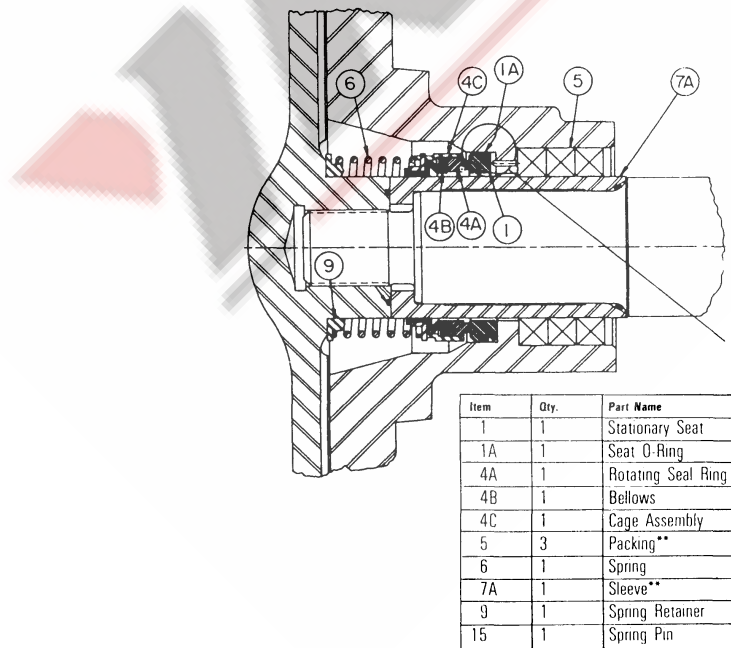

**These items are not included with seal

Figure 9

Maintenance ...

IV. ASSEMBLY

F. MECHANICAL SEAL (Continued)...

2. H25001-1

- a. Follow steps 1 through 5 above to install the stationary.
- b. Place the impeller suction side down and hub side up.
- c. Lubricate the inside of rubber bellows of the seal. Firmly slide the entire rotating seal assembly onto the impeller hub until the rubber bellows butts against the back of the impeller.
- d. Make sure no foreign material is present on the seal faces.
- e. Thread the impeller (2) onto the shaft (7). Tighten to approximately 160 ft./lb. of torque. It is easiest with a NATIONAL OILWELL Impeller Wrench (Part H20592).
- f. Install the casing gasket (1A). Hold it in place with grease if necessary. Apply a light coat of anti-seize compound on the 14-1/8 diameter of the stuffing box cover. Install the casing (1) on the frame using studs (1C) and nuts (1B). Put a small quantity of anti-seize compound on the threads on the nut end of the studs. Tighten nuts to 140 ft./lb. of torque using a criss-cross tightening pattern.

V. EXCESSIVE PACKING LEAKAGE and RAPID PACKING WEAR

A. GENERAL

Most early packing failures are caused by over-tightening or poor installation.

B. PACKING APPEARANCE

If the packing being removed is hard and brittle, it has been run dry some time in its life. This is often done in the first hour of service. The packing has more ability to grow with heat during its early life. Even if the packing is adjusted just right before starting the pump, in the first few minutes of operation the packing will grow with heat and become over-tight. It will then run drop-tight and the packing will burn. ONCE THE PACKING IS BURNED IT WILL NEVER SEAL PROPERLY AGAIN. Let new packing leak more in the first few hours and then adjust it to 10-12 drops per minute.

Maintenance (Continued)...

VI. INSTALLING WATER FLUSH SYSTEM TO BE ACCEPTABLE BY OIL COMPANIES

A. GENERAL

Many oil operators will not allow water to be put on the packing because of excess water getting into the mud, a result of poorly designed and maintained systems. Two major problems cause this complaint:

1. Too much line pressure
2. Not turning water off when pump is not in use.

B. CONTROLLING WATER PRESSURE TO THE PACKING

The water pressure is usually too high. The brake cooling pump is normally used which operates at pressures from 50 to 75 psi. Only 5 to 10 psi water is needed to cool and lubricate the packing. A pressure regulator should be installed to reduce the pressure on the packing. One regulator can supply all centrifugal pumps from a central system.

C. CONTROLLING WHEN TO USE WATER ON PACKING

LARGE VOLUMES of water get into the mud when the pump is NOT OPERATING. When the pump is running, the shaft deflects and when stopped, the shaft straightens up and a gap occurs down one side of the shaft between the packing and the shaft. This allows a stream of water to enter the mud. You can manually turn off the water when the pump is shut down but a better way is to install a solenoid valve in the water supply line that turns the water on and off as the motor is turned on and off. Only a small amount of water (a few drops per minute) which gets into the mud while the pump is running should not be objectionable to the oil companies.

VII. BEARING FAILURES and HOW TO IMPROVE BEARING LIFE

A. GENERAL

Except for cavitation problems, bearing failure is the greatest cause of increased pump operating cost. If you continue to run a pump when bearing failures occur, there is an excellent chance the entire pump will be destroyed. Therefore it is very important to change the bearings when failure **starts**. If you wait for complete failure other fluid end parts will be damaged. Bearing failure is more often caused by **lubrication failure** than by normal bearing wear.

B. MISALIGNMENT BETWEEN PUMP and DRIVER

A major cause of bearing failures is misalignment. Alignment between the pump and motor should always be checked after shipment and periodically rechecked.

C. DETECTION OF BEARING FAILURE WHEN PUMP IS RUNNING

The first indication of lubricant and bearing failure is a rapid rise in operating temperature. You should feel the frame once a week to get a feel for how hot the bearings normally run. A sudden high increase in temperature normally means the bearings are beginning to fail and need changing.

You cannot hold your hand for very long on unsatisfactory temperatures. If you can keep your hand on the housing for 5 seconds the temperature is about 160° F. which is suitable for most pumps. If you cannot hold your hand on the housing for five seconds or if the bearing housing is so hot you do not want to touch it, there is most likely lubricant and/or bearing failure.

Miscellaneous Information...

I. OPERATING LIMITS OF RIG CENTRIFUGAL PUMPS

As with any type of equipment, centrifugal pumps have operating limits. Observing these limits will extend the life of your pumps.

II. SUCTION LINE VELOCITY

Suction line velocity should not exceed 8.5 feet/second for reasonable pump life. This means the maximum flow for a 6 inch suction is 900 GPM and an 8 inch suction is 1600 GPM. If you want to flow more than 1600 GPM a 10-inch or larger suction line should be installed.

III. NET POSITIVE SUCTION HEAD (NPSH)

The system must have enough NPSH for the pump requirements or the pump will cavitate, greatly reducing its life.

It appears that most installations do not have enough NPSH to run a 5x6 pump at flows above 1400GPM even with an 8-inch suction. (This does not mean that no one has enough NPSH). The result of inadequate NPSH is cavitation and early pump failure.

IV. CAPACITY LIMITS OF PUMPS

Capacity limits for pumps listed below do not consider suction line velocity or NPSH calculations which must be made for every installation.

PUMP SIZE	MAXIMUM GPM
3x2x13	450
4x3x13	750
5x4x14	1100
6x5x14	1800
8x6x14	2400

Miscellaneous Information (Continued)...

V. CAPACITY REQUIREMENTS OF EQUIPMENT IN RIG APPLICATIONS

The chart below lists the normal design requirements when the equipment is new with no wear.

EQUIPMENT	DESIGN VOLUME
4" CONE	60 GPM
4H (5") CONE	80 GPM
6" CONE	125 GPM
8" CONE	250 GPM
10" CONE	500 GPM
6" MUD HOPPER	550 GPM
¾" NOZZLE	80 GPM
1" NOZZLE	150 GPM
1 ½ " NOZZLE	300 GPM
2" NOZZLE	550 to 600 GPM
MECHANICAL BRAKES	40 to 50 GPM
ELECTRIC BRAKES	50 to 200 GPM
SWACO DEGASSER	400 GPM
WELCO DEGASSER	700 GPM
BRANDT DG5 DEGASSER	500 GPM
BRANDT DG10 DEGASSER	1000 GPM

VI. LONG TERM PUMP and MOTOR STORAGE

Pump packages should be stored indoors in a clean, dry and protected environment.

1. The storage area is to be free from any vibration and temperature extremes.
2. Motor and pump shafts are to be rotated manually every two months. A record of the rotation should be made.
3. Grease in the motor and the pump bearings is to be purged at the time of removal from storage and replaced with an ample supply of fresh grease in each grease cavity.
4. Motor windings should be megged at the time the equipment is placed in storage. At the time of removal from storage the resistance reading must not have dropped more than 50% from the initial reading. Any drop below this point necessitates electrical or mechanical drying of the motor windings. Condensation from hot days and cool nights can fill the motor half full with water. This is a greater potential problem in damp areas.
5. If the pumps are to be stored outdoors, the pump suction and discharge openings should be sealed to prevent any water from entering the pump housing. This will prevent rust and corrosion.

Olympia™ Double Mechanical Seals...

I. GENERAL

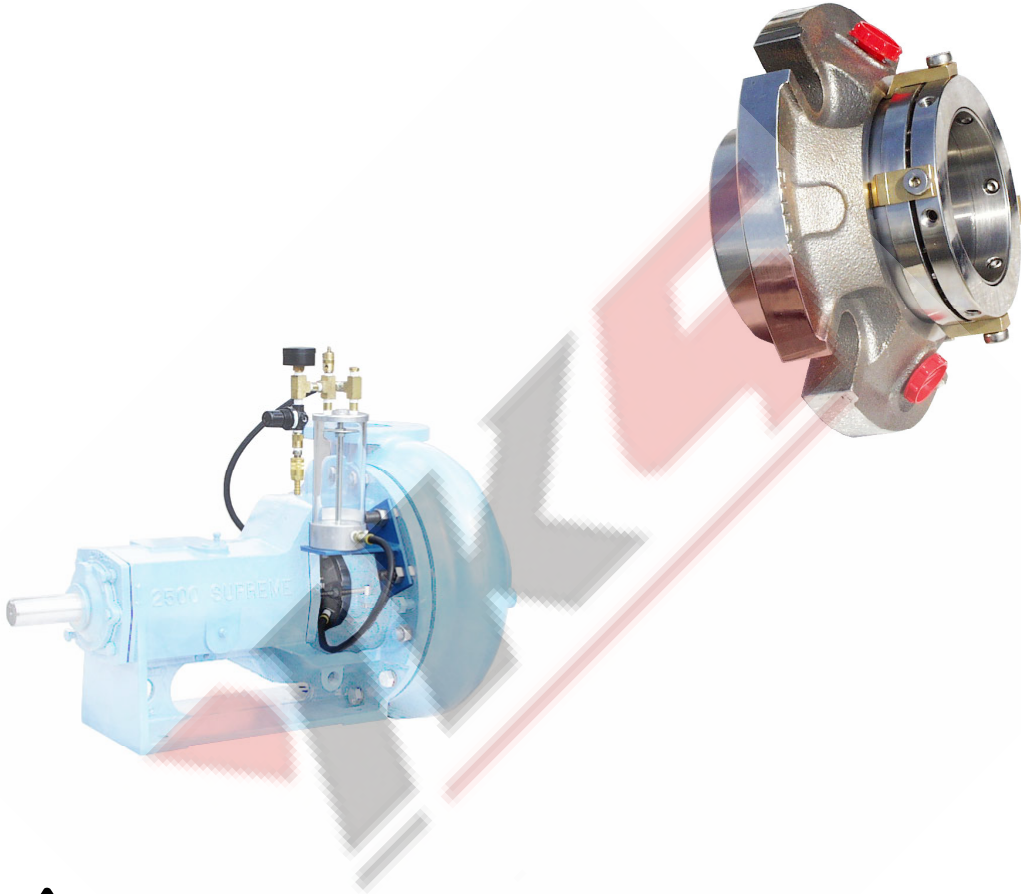

! WARNING ! WARNING ! WARNING !

Disconnect and lockout all electrical/mechanical power to the pump prior to performing any maintenance activities. Do not proceed until you have read these instructions and if you have any questions do not continue but contact the nearest Mission representative for assistance.

Installation, Operation and Maintenance Instructions

Olympia™ Double Mechanical Seals...

I. GENERAL (Continued)...

A. EQUIPMENT LIST

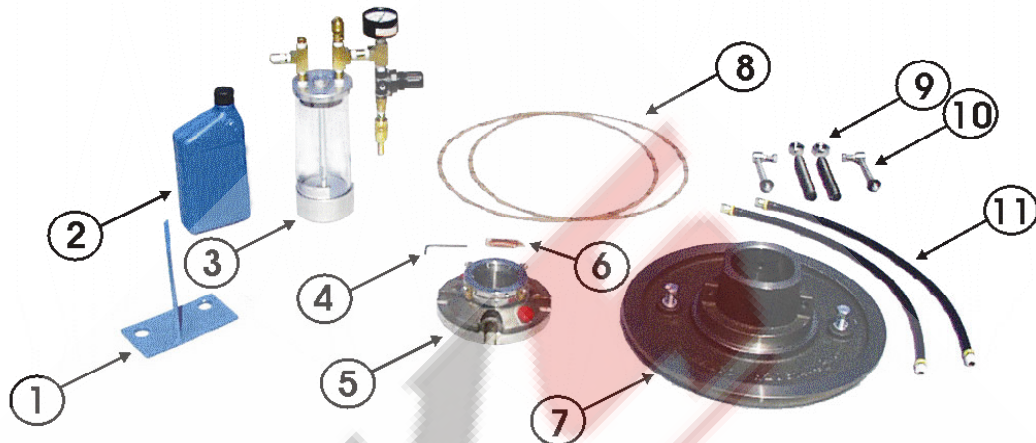

1. Barrier Fluid Reservoir Bracket	30182-4-4 1/4" Male Push Lock	2
2. Use water or water and glycol for barrier fluid	30682-4-4 1/4" Female Push Lock	2
3. Barrier Fluid Reservoir Assembly	31618H pressure Regulator	1
4. Allen Wrench	31619H 0-160 PSI Press. Gauge	1
5. Olympia™ Double Mechanical Seal	31620H 65 PSI Relief Valve	1
6. Lubricant	44FTX-S 1/4" Male NPT x 1/4" JIC.....	1
7. Stuffing Box	46FTX-S 3/8" Male NPT x 1/4" JIC.....	1
8. Casing Gasket	6D917 Check Valve	1
9. Bracket Studs and Nuts	HOSE 25" x 1/4" 1/4" Male NPT x 1/4" Female Swivel	2
10. Gland Bolt Assembly	HZC 1/4" x 1/4" Male NPT hose Connector	1
11. Feed and Return Hoses	1/4"-20 x 1" Hex Head Cap Screw.....	2
	1/4" Lock Washer.....	2
	Bb250-5B 20 Series Female Coupler.....	1

B. PART NUMBERS

RS Bracket

1. P/N KCD SEAL Assembly Includes:
 - 31617H Barrier Fluid Reservoir..... 1
 - 215PN-4 1/4" close Nipple
 - 215PNL-4-15 1/4" Long Nipple..... 3
 - 2203P-4 Female Tee..... 3
 - 22451DS Olympia Seal
 - 218P4 1/4" Plug NPT HX

2. Allen wrench
3. 22451-DS
4. Lubricant

5. 648403012 Casing Gasket
6. 3932-61H SS Nut & ##### 5" Stud
7. 601102494 Gland Bolt Assy.
8. Hose 20" x 1/4"

Olympia™ Double Mechanical Seals (Continued)...

II. INSTALLATION AND OPERATIONAL PROCEDURES

! WARNING ! WARNING ! WARNING !

Disconnect and lockout all electrical/mechanical power to the pump prior to performing any maintenance activities. Do not proceed until you have read these instructions and if you have any questions do not continue but contact the nearest Mission representative for assistance.

NOTE: The Olympia seal set screws lock onto the shaft between the stuffing box and inboard bearing cap. This area of the shaft must be clean and perfectly round. If the shaft is corroded in this area the seal will not center properly and may fail prematurely. Replace shaft if this area of the shaft is damaged.

1. Remove casing nuts and casing from pump.
2. Remove Impeller from pump. If equipped the anti-loosening bolt in the front of the impeller must be removed by turning in a clockwise direction (this is a left hand bolt). Remove impeller by turning in counter clockwise direction while holding shaft. Note: Impeller removal wrench part number 20652H is very useful for this procedure.
3. Remove stuffing box by removing two stuffing box bolts and then pulling stuffing box away from power frame.
4. Remove the grease zerk from the front of the inboard bearing cap.
5. Inspect shaft sleeve and shaft sleeve o-ring for damage and replace if necessary. Be sure to coat ID of shaft sleeve with anti-seize compound to simplify future removal.
6. Remove red plastic port plugs from the 22451-DS Olympia Seal gland.
7. Ensure 20614DS stuffing box ID and top are clean and free from debris.
8. Center 22451DS seal, gasket side down into the ID of the 20614DS stuffing box.
9. Install 601102494 Gland bolts through stuffing box ears and through 22451 DS gland. **FINGER TIGHTEN GLAND BOLT NUTS ONLY.** Seal assembly must be able to move so it can center itself on shaft during installation.
10. Coat ID of power frame and machined OD of stuffing box with anti-seize compound.
11. Coat the ID of the double mechanical seal sleeve with the lubricant provided.
12. Gently slip the stuffing box and seal assembly over the shaft sleeve until the stuffing box is square and flush against the power frame. **DO NOT INSTALL STUFFING BOX BOLTS AT THIS TIME.**
13. Teflon tape the male threads of both hoses.
14. Rotate stuffing box so the seal gland ports are accessible and thread the hoses into the gland and tighten firmly.
15. Rotate stuffing box back to its proper position, install stuffing box bolts and tighten firmly.
16. Firmly tighten gland bolts, permanently stabilizing the double seal. Be sure to tighten all four nuts.

Olympia™ Double Mechanical Seals...

II. INSTALLATION AND OPERATIONAL PROCEDURES (Continued)...

17. Inspect the impeller o-ring and replace if necessary.
18. Screw the impeller onto the shaft in a clockwise direction.
19. If equipped thread the impeller anti-loosening bolt through front of impeller into the shaft and tighten firmly in a counter clockwise rotation.
20. Adjust the impeller clearance so the impeller is .020" from the stuffing box. (See pump maintenance instructions for detail on adjusting the impeller clearance)
21. Once the impeller clearance is set, use the Allen wrench provided to tighten the double mechanical seal set screws. **DO NOT ROTATE THE SHAFT WHILE THE CENTERING CLIPS ARE INSTALLED OR SCORING OF THE SEAL FACE CAN OCCUR.** There are (6) set screws that must be tightened. Tighten the accessible screws first using a cross alternating pattern. A minimum of four opposing setscrews must be tightened before removing the centering clips. Once accessible setscrews are tightly set remove the centering clips.
22. Remove the four brass centering clips shown in Figure 1 (Do not rotate the shaft when the set screws are set and centering clips are installed). Once all centering clips have been removed rotate the shaft to tighten the remaining set screws. Be sure all 6 set screws are tightened. **RETAIN THE CENTERING CLIPS FOR FUTURE USE.** Centering clips are required when removing the seal from the stuffing box.

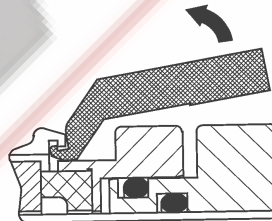

Figure 1

23. Replace existing studs in the casing with the 5" studs provided in the 2:00 and 2:30 position.
24. Coat the OD of the stuffing box wear plate with an anti seize compound.
25. Position the casing gasket within the ID of the casing (gasket can be held in place using a small amount of grease in the 12, 3, 6, and 9 o'clock positions).
26. Install casing onto power frame and tighten casing nuts using a cross alternating pattern.
27. Install the Barrier Fluid Reservoir Bracket onto the 5" casing studs and thread the additional casing nuts provided to hold in place. Tighten nuts firmly.
28. Bolt the Barrier Fluid Reservoir Assembly onto the Barrier Fluid Reservoir Bracket using bolts provided and tighten firmly.
29. Wrap the barrier fluid reservoir male feed and return ports with Teflon tape.

Olympia™ Double Mechanical Seals...

II. INSTALLATION AND OPERATIONAL PROCEDURES (Continued)...

30. Attach the feed hose from the bottom of the seal gland to the bottom feed port of the barrier fluid reservoir.
31. Attach the return hose from the top of the seal gland to the top return port of the barrier fluid reservoir.
32. Re-install the grease zerk into the front of the bearing cap.
33. Remove the fill plug from the top of the Barrier Fluid Reservoir.
34. Insert funnel into fill port and fill with 1 pint of water (or water glycol solution for freezing environments). Note: pulling the pressure relief valve open while filling will increase the fill rate.
35. Tape the fill plug with Teflon tape and re-install. Tighten firmly.
36. Pull knob on pressure regulator to unlock adjustment. Turn knob counter clockwise until stops then turn knob clock wise 1 1/2 full turns.
37. Attach air hose to air inlet port and charge barrier fluid reservoir with air. Air Supply should be free of moisture and oil. Barrier fluid level will drop slightly as hoses and seal fill with fluid.
38. Turn pressure regulator knob clockwise until gauge reads 40 PSI. Push regulator knob in to lock in position.
39. Remove air line if desired.
40. Check seal, hoses and other fittings for leaks.
41. Check pressure gauge and ensure pressure is holding at 40 PSI.
42. Return pump to service.
43. Barrier fluid level should be maintained between $\frac{1}{4}$ and $\frac{1}{2}$ full. **Warning!!** When re-filling reservoir turn off the pump and lockout power source. It is critical that the air pressure be removed from the reservoir prior to attempting to re-fill it. To do this first disconnect air inlet from source, relieve vessel pressure by pulling pressure regulator knob out and turning all the way to the left (counter-clock wise), pull ring on pressure relief valve to ensure all pressure has been relieved, after ensuring that the pressure is released remove fill plug and fill reservoir.
44. Once reservoir has been refilled repeat steps 35 thru 42.

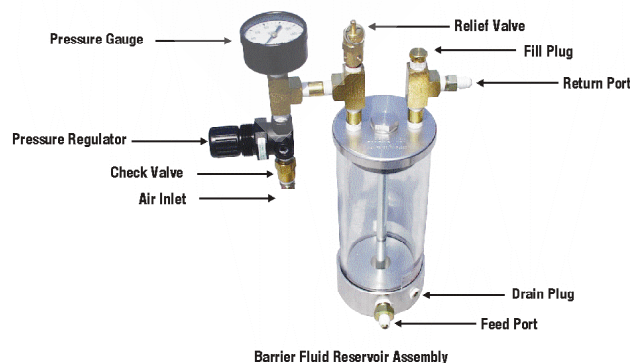

Olympia™ Double Mechanical Seals (Continued)...

III. REMOVAL PROCEDURES

NOTE: The Olympia Double Mechanical Seal can be successfully removed from a worn stuffing box and re-installed into a new stuffing box if the following procedures are followed. The factory can also rebuild the seal if the following procedures are followed.

1. Turn off pump and lock out power source.
2. Disconnect air source from air inlet of barrier fluid reservoir
3. Close suction and discharge valves and remove pump from line.
4. Pull out knob on pressure regulator relief valve and turn counter clockwise until air pressure gauge reads zero. **Pull ring on pressure relief valve to ensure all pressure has been relieved.**
5. Unbolt Barrier Fluid Reservoir from the Barrier Fluid Reservoir Bracket.
6. Remove drain plug and drain barrier fluid into appropriate container. (Pull ring on pressure relief valve to accelerate draining of vessel)
7. Uncouple fill and return hoses from the Barrier Fluid Reservoir and drain into appropriate container.
8. Teflon tape the drain plug and replace in Barrier Fluid Reservoir and tighten firmly.
9. Remove the Barrier Fluid Reservoir Bracket from frame.
10. Remove casing nuts and casing from frame.
11. Remove impeller from pump. If equipped the anti-loosening bolt in the front of the impeller must be removed by turning in a clockwise direction (this is a left hand bolt). Remove impeller by turning in counter clockwise direction while holding shaft. Note: Impeller removal wrench part number 20652H is very useful for this procedure.
12. Locate brass-centering clips originally sent with seal.
13. **Do not rotate the shaft with the centering clips installed until the setscrews have been loosened. Rotating the shaft with centering clips and tightened setscrews could score the seal face.** Install brass-centering clips as shown in figure 2. NOTE: There are (4) centering clips and (10) female threaded ports that they will fit. You must install the clips in the correct female ports. The female ports are located in the 3, 6, 9, and 12 o'clock positions on the Olympia Seal above the gland. Two of the proper holes have a flat head anti-tampering screw in them and two of the holes are empty. **DO NOT INSTALL THE CENTERING CLIPS IN HOLES THAT HAVE THE ALLEN HEAD SET SCREWS IN THEM.**

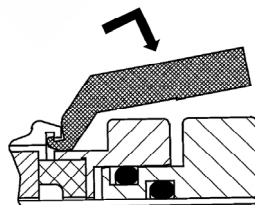

Figure 2

Olympia™ Double Mechanical Seals...

III. REMOVAL PROCEDURES (Continued)...

14. Remove the grease zerk from the front of the inboard bearing cap.
15. Loosen (6) Allen head shaft set screws on the Olympia seal. **NOTE: THE CENTER CLIPS MUST BE IN PLACE BEFORE LOOSENING THE SET SCREWS.**
16. Remove the stuffing box bolts.
17. Rotate the stuffing box so you can easily access the hoses and remove the hoses from the Olympia Seal gland.
18. Carefully remove the stuffing box and mechanical seal from the pump.
19. Loosen the gland bolts and remove the Olympia Seal from the stuffing box.
20. Follow procedures defined in Part I Installation instructions steps 5 and steps 7-41.

Cross Section Drawing...

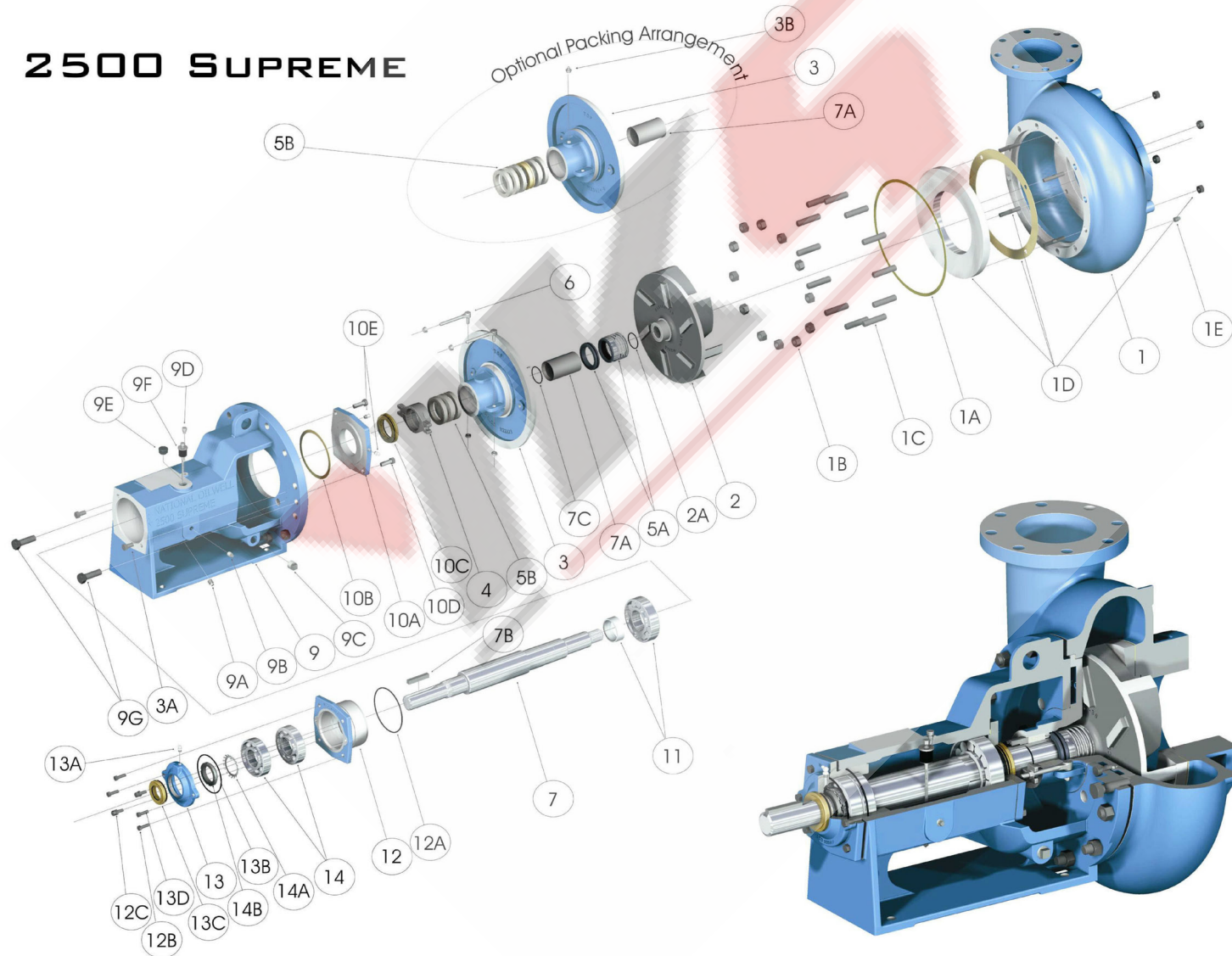

Figure 10

Installation, Operation and Maintenance Instructions

Parts List...

Item	Qty	Part Number	Process #	Description	Material	Item	Qty	Part Number	Process #	Description	Material
1*	1	See Below	See Below	Casing, Includes 1 thru 1E	Hard Iron	13A	1	N/A	661010020	Grease Zerk, O.B. Brg. Cvr.	Steel
1A	1	10399-46-1	648403012	Gasket, Casing	Vellumoid	13B	1	H7496-26	072200017	O-ring, O.B. Bearing Cover	Buna-n
1B	12	3932-61	3932-61H	Nut, Casing	Stainless Steel	13C	1	H2564-3	2564-3H	Labyrinth Seal, O.B. Brg. Cv	Buna-n
1C	12	H2507-3	648401115	Stud, Casing	Steel	13D	2	H3861-139	3861-139-4	Bolt, O.B. Brg. Cover	Stainless Steel
1D*	1	See Below	See Below	Wear Pad, Includes studs, nuts & gskt	Iron	14	1	H20616-1S	648408201S	Bearing, O.B. (2 PER SET)	Vendor
1E	1	8505-2H	601474703	Plug, Casing Drain	Steel	14A	1	H6124-4	648402105	Lockwasher, O.B. Bearing	Steel
2*	1	See Below	See Below	Impeller	Hard Iron	14B	1	H6123-4	648402055	Locknut, O.B. Bearing	Steel
2A	1	H19110-72	648405082	Seal, Impeller	Viton	Casings - Includes Studs, Nuts & Gasket					
3*#	1	H22223-01-30	22223H	Stuffing box, Mech. Seal	Ductile Hard Iron	1*	1	H19203-01-30A	19203AH	Casing, 3x2x13	Hard Iron
3*&	1	H20614-01-30	20614H	Stuffing Box, Packed	Ductile Hard Iron	1*	1	H19205-01-30A	19205AH	Casing, 4x3x13,w/ wear pad	Hard Iron
3A	2	H3861-117	3861-117	Bolt, Stuffing box	Steel	1*	1	H19222-01-30A	19222AH	Casing, 5x4x14,w/ wear pad	Hard Iron
3B&	1	19368-1H	19368-1H	Grease Fitting	Steel	1*	1	H19122-01-30A	19122AH	Casing, 6x5x11,w/ wear pad	Hard Iron
4	1	H20622-4A	20622AH	Gland Assy., Packing	Stainless Steel	1*	1	H19123-01-30A	19123AH	Casing, 6x5x14,w/ wear pad	Hard Iron
5A#	1	H22451-1A	22451K	Seal, Mechanical	Tungsten Carbide	1*	1	H19763-01-30A	19763AH	Casing, 8x6x11,w/ wear pad	Hard Iron
5B~	1	8264-24-OB	648402600	Packing, Shaft	Packing	1*	1	H19117-01-30A	19117AH	Casing, 8x6x14,w/ wear pad	Hard Iron
6	2	20629	601102494	BOLT, GLAND	Steel	1*	1	H20937-01-30A	20937AH	Casing, 10x8x14,w/ wear pad	Hard Iron
7	1	H20612-02-33	646490557	Shaft	AISI 4140	Impellers and Casing Wear Pads					
7A#	1	H20613-21A	646492505	Sleeve, Shaft (M.S. Pump)	416SS	2*	1	H19204-XX-30	Varies	Impeller, 3x2x13 Open	Ductile Hard Iron
7A&	1	H20613-21G-7A	646490656	Sleeve, Shaft (Pack Pump)	416SS/Ceramic	2*	1	H19206-XX-30	Varies	Impeller, 4x3x13 Open	Ductile Hard Iron
7B	1	H4372-5-21	601212392	Key, Shaft	416SS	2*	1	H2523-XX-30	Varies	Impeller, 5x4x14 Semi Open	Ductile Hard Iron
7C	1	23444-01-72	648415156	Seal, Shaft Sleeve	Viton	2*	1	H2524-XX-30	Varies	Impeller, 6x5x11 Semi Open	Ductile Hard Iron
8	1	22210-1A	641116108	Deflector Assembly	Bronze	2*	1	H2524-XX-30	Varies	Impeller, 6x5x14 Semi Open	Ductile Hard Iron
9	1	H17444	17444H	Frame, Grease Lubricated	Cast Iron	2*	1	H2524-XX-30	Varies	Impeller, 8x6x11 Semi Open	Ductile Hard Iron
9A!	1	H8505-1	8505-1	Plug, Oil Drain	Iron	2*	1	H2525-A0-30	Varies	Impeller, 8x6x14 Semi Open	Ductile Hard Iron
9B!	1	8505-2H	601474703	Plug, Oil	Iron	2*	1	H2526-XX-30	Varies	Impeller, 10x8x14 Semi Ope	Ductile Hard Iron
9C	1	N/A	601474737	Plug, Frame Drain	Iron	1E	1	H2501-01-30A	2501-37AH	Wear Pad, 4X3X13 Casing	Ductile Hard Iron
9D	1	H8267-1	601473689	Breather	Steel	1E	1	H2502-01-30A	2502-37AH	Wear Pad, 5X4X14 Casing	Ductile Hard Iron
9E	1	H2565-1	2565-1H	Plug, Oil Fill	Plastic	1E	1	H2503-01-30A	2503-37AH	Wear Pad, 6X5X11 Casing	Ductile Hard Iron
9F!	1	H2539-3	2539-3H	Dip Stick	Steel	1E	1	H2504-01-30A	2504-37AH	Wear Pad, 6X5X14 Casing	Ductile Hard Iron
9G	2	H2538-1	2538-1H	Bolt, Casing Jack	Steel	1E	1	H2505-01-30A	2505-37AH	Wear Pad, 8X6X11 Casing	Ductile Hard Iron
10A	1	H17950	17950H	Cover, Inboard Bearing	Iron	1E	1	H2506-01-30A	2506-37AH	Wear Pad, 8X6X14 Casing	Ductile Hard Iron
10B	1	H20625	648408706	Gasket, I.B. Brg. Cover	Vegetable Fiber	1E	1	H2527-01-30A	2527-37AH	Wear Pad, 10X8X14 Casing	Ductile Hard Iron
10C	1	H2564-4	2564-4H	Labyrinth Seal, IB Brg Cvr	Buna-n	XX - Imp. Code - First X equals diameter of impeller in inches minus 4. Therefore 10" = 6, 9" = 5, 8" = 4, etc...14" use letter A. Second X equals fractional data in 1/8's. Therefore 1/8" = 1, 1/4" = 2, 1/2" = 4, etc...Thus a 10.5" impeller is coded as 64					
10D	2	H3861-1	3861-1H	Bolt, I.B. Brg. Cover	Steel						
10E	1	N/A	661010033	Grease Fitting	Steel	Notes:					
11	1	N/A	661009010	Bearing, Inboard	Vendor	* - Casings, Imp. & Stuff Boxes are available as Supreme Hard or Aluminum Bronze					
12	1	H20624-01-01	20624H	Housing, O.B. Bearing	Iron	# - Used for pumps equipped with mechanical seal only.					
12A	1	H7496-253	648402295	Seal, O.B. Brg Housing	Buna-n	& - Used for pumps equipped with packing only.					
12B	4	H3861-138	3861-138	Bolts, O.B. Brg. Housing	Steel	! - Used for oil lubricated pumps only.					
12C	2	H3932-62	658404702	Nut, O.B. Brg. Housing Jam	Steel	~ - Packing available in various materials - standard material shown					
13	1	H20617A	20617H	Cover, O.B. Bearing	Ductile Iron						



With over 120 locations worldwide, National Oilwell is located near you. To find the nearest Distribution Service Center, machinery center or repair facility, please give us a call at our main office listed below.

Or you can access our website at the URL listed below, where you may search by location or country.

www.en.sdyks.cn

Sales/Technical Information:

Internet: www.en.sdyks.cn

National Oilwell is a leading manufacturer of reciprocating plunger pumps, centrifugal pumps, and fluid end replacement parts. We also offer a complete set of solutions to fluid transfer challenges. For more information, contact National Oilwell directly at the Headquarters in Houston, Texas. All National Oilwell products are available throughout the U.S. and around the world from service centers, authorized distributors, and representatives.

© Copyright 1999 by National Oilwell, L.P. All Rights Reserved. NATIONAL OILWELL, NATIONAL, and OILWELL are registered trademarks of NATIONAL OILWELL, L.P. Houston, Texas, USA. All other trademarks used are registered to their respective companies. The information and data in this brochure, including but not limited to pictures, photographs, charts, diagrams, drawings, lists, written comments, and specifications, are accurate to the best of our knowledge and belief, but are intended for general information only. Applications suggested for the materials and other information are described only to help readers make their own evaluations and decisions, and are neither guarantees nor are they to be construed as express or implied warranties of suitability for these or other applications. National Oilwell makes no warranty, either express or implied, beyond that stipulated in National Oilwell's Standard Terms and Conditions of Sale which are available upon request.